



Modular Explosion Proof Brakes

**YOUR
MOTORS
OUR
BRAKES**



NEMA Line

The background of the entire page is a close-up photograph of a blue industrial machine. The machine has a textured surface and several circular ports or openings. The word "INDEX" is printed in white, bold, uppercase letters in the upper center of the image.

INDEX

PAG1

About VIS

PAG2

Application example, Main characteristics, Standards

PAG3

Certificates and options

PAG4

Identification and technical data

PAG5

Technical data - performance

PAG6

Overall Dimansions



Explosion proof Brakes

A product invented and produced by Coel Motori, Milano, Italy

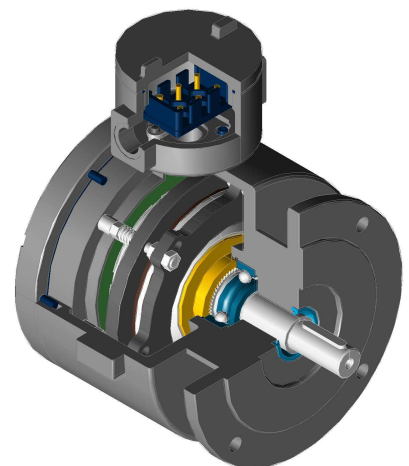

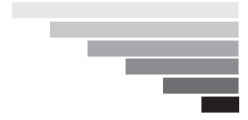

About VIS

VIS is a product of COEL, specialized manufacturer of brake motors located in Italy. Since 1976 COEL designed and manufactured brake motors making all the components including the brake units in its facilities (see www.coelmotori.it for further details).

Thanks to this large experience, on 2005 we invented VIS, the modular ATEX brake system. Our idea was based on the market demand of a easy solution to make a brake motor without modification of the motors or extension of the certificates.

With more than 30 years of experience in manufacturing brakes, we defined a new oversized standard, able to guarantee a range of modular brakes designed for heavy duty. More than 35 controls made in the production process make each VIS brake as a master piece. All the components are tested 100%, all the working parameters controlled with functional tests made on each brake.

The VIS brakes range is in continuous development in order to make the quality and performance better and better.

For hoisting, travelling, positioning in Hazardous location the VIS brakes are the safe and reliable solution.

What's VIS?

The VIS Atex brake is an **innovative** modular flameproof spring applied disc brake unit. The **new** concept is to apply an independent brake unit to a standard flanged explosion proof motor or to a transmission unit. The flanges input and output follow both IEC or NEMA standards. The VIS brakes are certified as independent components. It means that there are not coupling procedures in order to define the certification.

Why VIS?

The VIS brakes are available in B5 flange face to face version (IEC 63 to 280), NEMA standards (56 to 405) and compact version for mounting in the rear part of a motor or to a transmission unit. This catalogue is related to NEMA Line.

Choosing the VIS brake, it's very **easy** to make an explosion proof brake motor, reducing costs and delivery time.

The performance of VIS brakes is particularly high and the **strong** structure makes them suitable for very heavy duty and for every kind of application (hoisting, travelling, positioning...). VIS brakes **don't need periodical maintenance** such as adjustment of gap on work site.

The braking torque values are included between 7 to 575 ft/lbs (depending on frames).

The **cost** of a standard explosion proof motor plus the VIS brake is considerably **lower** than an explosion proof brake motor and the delivery time and reliability are much better.

Application example

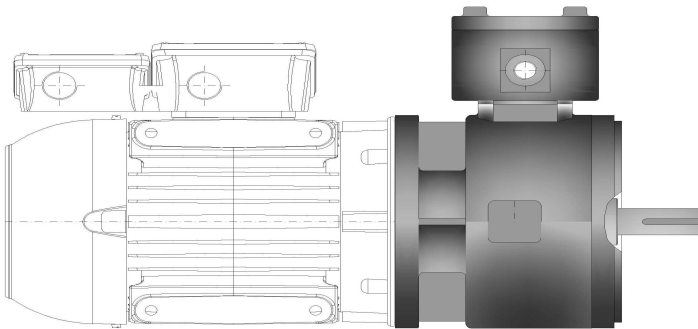

NEMA motor
+
VIS NEMA
=
High Performance Brake Motor

Main Characteristics

- PATENT pending design and concept system
- DC electromagnets with patent pending reconnectable system VAC 210 to 480 all in one.
- Totally closed
- IP66
- Special voltages available
- F class insulation
- Thermally protected with dual metal protectors as standard
- Large terminal box with terminal board and built in rectifier
- Very high resistance structure
- Designed for S1 duty without ventilation

Standards

The VIS NEMA series brakes are designed and approved for the following directives:

- FM for US market DIRECTIVE FM 3600:2011; FM 3616:2011; FM 3615:2006; ANSI/IEC 60529:2004; FM 3810:2005; ANSI/ISA-61010-1 (82.02.01):2004
- CERTIFICATE **CSA 2542839**

■ Ordering a VIS brake ■

For ordering a VIS brake it's necessary to supply the following information:

- 1) Type of certification required and protection classes needed
- 2) Input and output flange / shafts dimensions
- 3) Voltage required
- 4) Brake torque required
- 4) Options required

All the brakes are available in different voltages and brake torque values

Please see the performance data in order to correctly identify the brake

■ Technical data ■

General information

The spring-applied brake VIS is a single-disk brake with two friction surfaces.

The compression springs create the braking torque by friction locking. The brake is released electromagnetically.

The spring-applied brake is designed for the conversion of mechanical work and kinetic energy in heating. For operation characteristics see related paragraph.

Manual release

The manual release is an option available, it gives the possibility to release the brake in absence of current. It is a mechanical lever mounted on 2 fulcrums points moving the mobile anchor.

Microswitch

The VIS brakes can be equipped with a microswitch for air-gap or wear monitoring or for hand release opening monitoring. The user must provide the corresponding electrical connection.

Thermistors

All the VIS brakes are equipped with a PTO thermal protection with temperature limit related to the temperature class of the brake required. It must always be connected when operating in order to prevent extra heating in hazardous areas.

In alternative, we can apply a PTC thermistor to have a constant monitoring of the brake temperature through an external PLC.

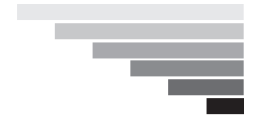

Technical data

Performance data (NEMA version)

FRAME	Nm* (min\max)	W	Engagement time	Braking time [ms]		Maximim RPM	
				DC Switching	AC Switching	Duty S1	Duty S3
56	10\15	50	12	20	120	3600	4100
143/5	15\25	50	20*	20	120	3600	4200
182/4	25\50	65	25*	90	250	3600	4200
213/5	50\80	65	30*	90	250	3600	4200
254/6	100\160	75	40*	180	500	3600	4000
284/6	160\240	100	50*	180	1080	2400	3600
324/6	250\370	210	90*	230	2300	1800	2200
364/5	400\650	210	90*	230	2300	1800	2200
404/5	560\780	210	160*	360	3800	1800	2200

Note: Nm x 0.7376 = ft/lbs

* values obtained with rectifier type WR2008

Braking time

VIS brakes are suitable for application with disk sliding of the disk of 0,5 seconds maximum. In case of longer time of sliding of the disk calculation, please contact us.

You can use the following formula in order to define the braking time:

$$\frac{J_{tot} \times n}{9.55 (M_f \pm M_{load})} + \frac{t_x}{1000}$$

J_{tot}: inertia moment at the motor shaft (Kgm²)

t_x: brake time response (ms)

M_{load}: resistant moment to the load applied (Nm), positive or negative depending on concordance with braking moment.

Note: for calculation of sliding time of the disc, consider the "t_x" value at "0".

n: speed r.p.m.

M_f: braking moment (Nm)

Brake choice

Dimensioning

The size of the brake is mainly determined by the braking torque and the relevant inertia of the load, braking time, speed, number of starts per hour.

The calculation of the brakes is generally related to the permissible friction energy. Since the VIS is an explosion proof unit, we simply defined a limit related to the maximum permissible sliding time of the disc in dynamic application.

This solution gives a simple parameter to choose the brake in a correct, easy and safe way.

If the brake is used as parking brake (coupled with a motor used with inverter), the calculation is not relevant except the value of brake torque necessary; we suggest always to consider a brake torque between 1,5 and 2,3 times the motor torque.

For further information or exact brake calculation choice, please contact us.

Voltages

The DC brakes of NEMA series are made with a special patent pending design system so to obtain on a single brake a voltage range between 210 to 480 VAC simply reconnecting the wires on the terminal board. Different coil voltages can be supplied on request.

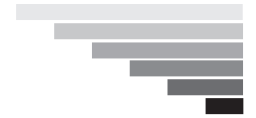

Connections

NEMA brakes are equipped with DC electromagnet; they are made with an exclusive system providing wide voltage range in one single reconnectable brake . All NEMA brakes are supplied as standard with WR2008 type rectifier providing fast engagement and release reaction times.

The built in rectifier allows to connect 2xVAC phase for an immediate and easy current supply. Connection diagrams are shown in the instrucion manual supplied with the brakes.

Overall dimensions (inch)

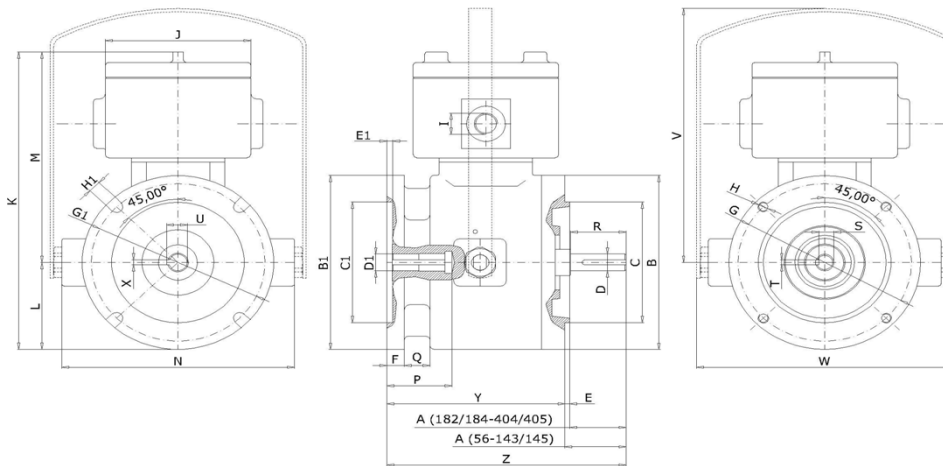

NEMA FRAME	56	143/145	182/184	213/215	254/256	284/286	324/326	364/365	404/405
A	2-1/16	2-1/8	2-5/8	3-1/8	3-3/4	4-3/8	5	5-5/8	7
B	6-1/2	6-1/2	9	9	10	11-1/4	13-3/8	13-3/8	13-7/8
B1	6-1/2	6-1/2	9	9	10	11-1/4	13-3/8	13-3/8	13-7/8
C	4-1/2	4-1/2	8-1/2	8-1/2	8-1/2	10-1/2	12-1/2	12-1/2	12-1/2
C1	4-1/2	4-1/2	8-1/2	8-1/2	8-1/2	10-1/2	12-1/2	12-1/2	12-1/2
D	5/8	7/8	1-1/8	1-3/8	1-5/8	1-7/8	2-1/8	2-3/8	2-7/8
D1	5/8	7/8	1-1/8	1-3/8	1-5/8	1-7/8	2-1/8	2-3/8	2-7/8
E	1/8	1/8	1/4	1/4	1/4	1/4	1/4	1/4	1/4
E1	0,196"	0,196"	0,220"	0,220"	0,220"	0,220"	0,220"	0,220"	0,220"
F	0,59"	0,59"	0,71"	0,71"	0,71"	0,79"	0,79"	0,79"	0,79"
G	5-7/8	5-7/8	7-1/4	7-1/4	7-1/4	9	11	11	11
G1	5-7/8	5-7/8	7-1/4	7-1/4	7-1/4	9	11	11	11
H	3/8"-16NC	3/8"-16NC	1/2"-13NC	1/2"-13NC	1/2"-13NC	1/2"-13NC	5/8"-11NC	5/8"-11NC	5/8"-11NC
H1	0,43"	0,43"	0,550"	0,550"	0,550"	0,550"	0,669"	0,669"	0,669"
I	1/2"NPT	1/2"NPT	1/2"NPT	1/2"NPT	1/2"NPT	1/2"NPT	1/2"NPT	1/2"NPT	1/2"NPT
J	4,92"	4,92"	4,92"	4,92"	4,92"	4,92"	4,92"	4,92"	4,92"
K	11,1"	11,1"	13,48"	13,48"	14,53"	15,785"	17,6775"	17,6775"	17,9275"
L	3,25"	3,25"	4,5"	4,5"	5"	5,625"	6,6875"	6,6875"	6,9375"
M	7,85"	7,85"	8,98"	8,98"	9,53"	10,16"	10,99"	10,99"	10,99"
N	7,87"	7,87"	10,35"	10,35"	11,10"	12,59"	/	/	/
P	2,244"	2,401"	2,972"	3,326"	4,094"	4,625"	5,393"	5,925"	7,16"
Q	0,86"	0,86"	1,57"	1,57"	1,57"	1,73"	1,81"	1,81"	1,81"
R	1-7/8	2-1/4	2-3/4	3-3/8	4	4-5/8	5-1/4	5-7/8	7-1/4
S	33/64	49/64	63/64	1-13/64	1-13/32	1-19/32	1-27/32	2-1/64	2-29/64
T	3/16	3/16	1/4	5/16	3/8	1/2	1/2	5/8	3/4
U	0,714"	0,965"	1,246"	1,527"	1,802"	2,105"	2,356"	2,657"	3,215"
V	9,85"	9,85"	10,98"	10,98"	11,53"	12,16"	/	/	/
W	8,87"	8,87"	11,35"	12,10"	12,10"	13,59"	/	/	/
X	3/16	3/16	1/4	5/16	3/8	1/2	1/2	5/8	3/4
Y	6,023"	6,023"	7,322"	7,322"	7,244"	8,832"	11,844"	11,844"	11,844"
Z	8,086"	8,148"	10,197"	10,697"	11,244"	13,286"	16,844"	17,469"	18,844"



a product of coel motori, via Campania 36/40 - Fizzonasco di Pieve Emanuele, Milano, Italy

Tel +39 02 90420039 Fax +39 0290420747

www.visbrakes.com info@visbrakes.com